



INSTRUCTIONS FOR

# BOTTLE JACKS 20/30TONNE AIR/HYDRAULIC

MODEL NO: **AM20.V3 & AM30.V3**

Thank you for purchasing a Sealey product. Manufactured to a high standard, this product will, if used according to these instructions, and properly maintained, give you years of trouble free performance.

**IMPORTANT:** PLEASE READ THESE INSTRUCTIONS CAREFULLY. NOTE THE SAFE OPERATIONAL REQUIREMENTS, WARNINGS & CAUTIONS. USE THE PRODUCT CORRECTLY AND WITH CARE FOR THE PURPOSE FOR WHICH IT IS INTENDED. FAILURE TO DO SO MAY CAUSE DAMAGE AND/OR PERSONAL INJURY AND WILL INVALIDATE THE WARRANTY. KEEP THESE INSTRUCTIONS SAFE FOR FUTURE USE.



Refer to instructions



Wear safety footwear



Chock wheels



Pump to raise  
Undo valve to lower

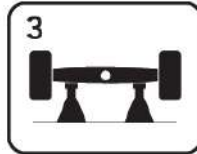

Use axle stands



To lower after use



Lubricate here

## 1. SAFETY

- WARNING! ALWAYS USE LOAD RATED STANDS TO SUPPORT LIFTED LOADS.**
- DANGER! Use the jack for lifting and lowering only.**
- DANGER! DO NOT place any part of the body under the lifted load unless the load is fully supported by rated stands, see symbol 3.**
- DANGER! DO NOT place any part of the body beneath the load during lifting and lowering.**
- DO NOT modify the jack in any way.**
- The load to be lifted should never exceed the rated capacity of the jack.
- The maximum stroke of the jack indicated on the label should never be exceeded.
- The jack should be supported on a solid, level and horizontal surface which is well illuminated and free of obstructions. Never stand the jack on a surface which may sink.
- The air supply hose should not be worn and connections should be in good condition. Keep the hose clean and away from heat, dirty areas or sharp edges and do not bend it.
- Ensure that there are no persons inside the vehicle to be lifted.
- Switch off the engine and apply vehicle handbrake (put automatics in Park).
- Ensure the vehicle or element to be lifted against any type of sliding. Use chocks.
- DO NOT** enter the vehicle or start the engine whilst it is supported on the jack or appropriate stands.
- Position the jack under the manufacturer's recommended lifting point for the vehicle and ensure that it is not corroded, dirty or greasy. This point should remain centred over the jack saddle. All off-centred loads can slip and accidents may result.
- During raising and lowering of the load, all precautions should be taken to avoid movement of the vehicle load. Traffic may cause the raised vehicle to rock during roadside use of the jack.
- It is necessary for the operator to be able to observe the lifting device and the load during all movements. In the presence of dangerous conditions, such as movement of the vehicle, etc, the lifting process must be interrupted.
- Ensure that there are no persons or obstructions underneath the vehicle prior to lowering.
- As an additional safety measure against overload, the jack is fitted with an overload valve set at the factory which should not be adjusted under any circumstances.
- Ensure that the jack is undamaged and in good working order.
- Keep the jack clean, particularly the load face of the saddle.
- Take immediate action to repair or replace any damaged parts.
- Use only approved parts/accessories obtained from a Sealey supplier. *The use of non-approved items could be dangerous and will invalidate the warranty.*
- Ensure that the jack is maintained by a qualified person and that the recommended hydraulic oil is used.

## 2. INTRODUCTION

Air hydraulic bottle jacks capable of both air assisted or manual operation. Fitted with safety overload valve and manufactured in the EU. All steel, one piece base, reservoir and air cylinder design gives added strength. Fully serviceable ram piston with extension screw. Both models supplied with 90° rotating pump and telescopic pump handle and have moulded carry handles incorporating storage for the pump handle. Service kits readily available.

## 3. SPECIFICATION

Model no: .....AM20  
 Capacity: .....20tonne  
 Minimum height: .....234mm  
 Maximum height: .....447mm  
 Piston stroke: .....138mm  
 Weight: .....15.5kg

Model no: .....AM30  
 Capacity: .....30tonne  
 Minimum height: .....242mm  
 Maximum height: .....455mm  
 Piston stroke: .....138mm  
 Weight: .....23.5kg

## 4. PREPARATION

- 4.1. **Connect air supply**
  - 4.1.1. An in-line filter is recommended, drain daily. Drain compressor tank daily.
  - 4.1.2. Before connecting air supply hose ensure trigger is not pressed down.
  - 4.1.3. Ensure constant air pressure is maintained during operation: 7-10 kg/cm<sup>2</sup> and a minimum air flow of 28ltr/min.
- 4.2. **Bleed system**
  - 4.2.1. Prior to using the jack, eliminate any air that may have accumulated in the system.
  - 4.2.2. Position the lever in the release valve and turn once in an anti-clockwise direction.
  - 4.2.3. Place the lever into the lever support and pump the jack several times to ensure internal lubrication and the elimination of accumulated air. Alternatively, press trigger A of the valve briefly.
  - 4.2.4. Place the lever in release valve again and close it in a clockwise direction.
  - 4.2.5. Jack is now ready for operation.

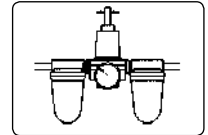

## 5. OPERATION

**IMPORTANT! Prior to lifting the load ensure that all of the above safety instructions are followed.**

- 5.1. The feed screw of the jack, compliments its stroke, **DO NOT** fully extend it.
- 5.2. **LIFTING**
  - 5.2.1. Close the release valve fully and press trigger of the air hose. Lifting may also be performed by fully moving the lever downwards to obtain greater speed by using the full stroke range of the piston.
- 5.3. **LOWERING**
  - 5.3.1. Slowly turn the release valve in an anticlockwise direction using the lever. Ensure that there are no persons or obstacles under the vehicle to be lowered.
  - 5.3.2. The lowering speed is controlled by the amount of the valve is opened.
  - 5.3.3. During lowering air is eliminated through a small hole in connector C, this is normal.
- 5.4. Should the jack be overloaded, it is fitted with an overload valve which will prevent the vehicle from being lifted.
- 5.5. Never move the jack with the lever in the release valve as this will cause damage.
- 5.6. **DO NOT** attempt to move the jack by pulling on the plastic air supply tube.

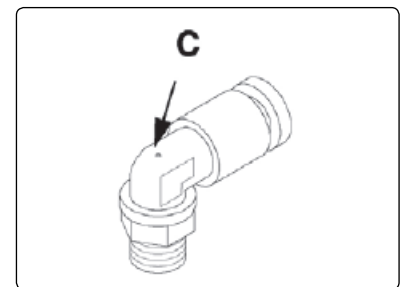

## 6. MAINTENANCE

**IMPORTANT!** Both the maintenance and repair of the jack may only be performed by qualified persons, who have sufficient knowledge of the hydraulic systems used in these devices as a result of their training and experience.

- 6.1. Keep the jack clean and lubricate all moving parts at regular intervals, which must be clean and protected from aggressive conditions at all times.
- 6.2. Only original spare parts should be used.
- 6.3. Prior to each use, check for bent, broken, cracked or loose parts and solve the problem. If it is suspected that the jack has been subjected to abnormal loads or has suffered any knocks, withdraw it from service until the problem has been rectified.
- 6.4. If the oil level needs to be checked or refilled, with the piston fully retracted, remove the filler plug and drain its contents into a container.
- 6.5. Refill with oil. Use a good quality oil such as Sealey hydraulic jack oil. **DO NOT** use brake fluid. Bleed system as in section 4.2. Replace oil filler plug. Ensure no dirt enters the hydraulic system when draining, filling removing or replacing components. Annual oil replacement is recommended for jacks in daily use.
- 6.6. **IMPORTANT** Too much oil may render the jack inoperative.
- 6.7. When the jack is not in use, the screw, main piston and the pump piston should be retracted to avoid corrosion.
- 6.7. Remove the handle from its position.

**IMPORTANT: NO RESPONSIBILITY IS ACCEPTED FOR INCORRECT USE OF THIS PRODUCT.**

*Hydraulic products are only repaired by local service agents. We have service/repair agents in all parts of the UK.*

**DO NOT RETURN PRODUCT TO US.** Please telephone us on 01284 757500 to obtain the address and phone number of your local agent.

*If product is under guarantee please contact your dealer.*

### De-commissioning Product

Should the product become completely unserviceable and require disposal, draw off the oil into an approved container and dispose of the product and the oil according to local regulations.

- 6.8. **Preventative maintenance**
  - 6.8.1. When the jack is not in use, keep piston and rod fully retracted. Store the jack on its base in an upright position, in a well protected area, where it will not be exposed to corrosion, abrasive dust, or other harmful elements.
  - 6.8.2. Visually inspect jack before each use. Take corrective action if any of the following are found:
    - a. Cracked or damaged housing
    - b. Excessive wear, bending or other damage
    - c. Leaking hydraulic fluid
    - d. Scored or damaged piston or rod
    - e. Incorrectly functioning swivel head or adjustment screw
    - f. Loose hardware
    - g. Modified or altered equipment

## 7. TROUBLESHOOTING

Problem	Cause	Solution
Erratic action	Air in system  Viscosity of oil too high Ram sticking or binding	With jack sitting on its base and ram retracted, bleed air from unit, see section 4.2 Change to lower viscosity oil Look for dirt or gummy deposits, leaks, misalignment, worn parts or defective packing.
Ram does not advance	Release valve is open Low/no oil in reservoir Air locked in system Load is above capacity of system	Close release valve Fill with oil and bleed system Bleed the system Use correct equipment
Ram extends only partially	Low oil level in reservoir Piston rod is binding.	Fill with oil to oil line and bleed system. Look for dirt, gummy deposits, leaks, misalignment, worn parts or defective packing.
Ram advances slowly	Pump not working correctly  Leaking seals	Take jack to authorised service centre for pump repair. Repair with seal kit
Ram advances but does not hold pressure	Pump check valve not working  Ram seals are leaking	Take jack to authorised service centre for seal replacement Repair with seal kit
Jack leaks oil	Worn or damaged seals	Repair with seal kit
Ram will not retract or retracts slowly	Release valve is closed Reservoir is too full Ram damaged internally	Open release valve Drain oil to correct level Take jack to authorised service centre for repair

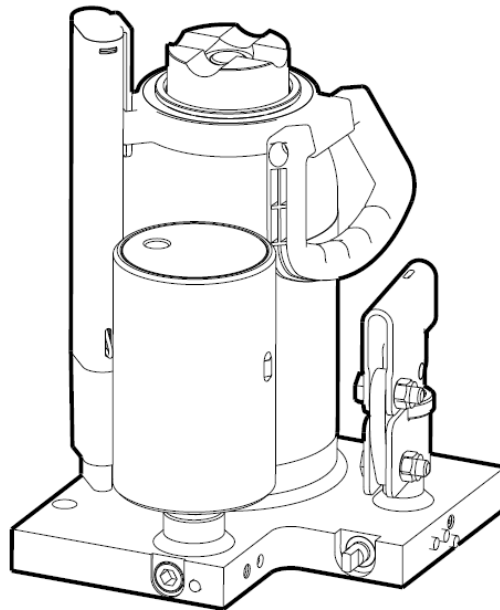

### Environmental Protection

Recycle unwanted materials instead of disposing of them as waste. All tools, accessories and packaging should be sorted, taken to a recycling centre and disposed of in a manner which is compatible with the environment. When the product becomes completely unserviceable and requires disposal, drain off any fluids (if applicable) into approved containers and dispose of the product and the fluids according to local regulations.

**NOTE:** It is our policy to continually improve products and as such we reserve the right to alter data, specifications and component parts without prior notice.

**IMPORTANT:** No liability is accepted for incorrect use of this product.

**WARRANTY:** Guarantee is 12 months from purchase date, proof of which will be required for any claim.



Sole UK Distributor, Sealey Group.  
Kempson Way, Suffolk Business Park,  
Bury St. Edmunds, Suffolk.  
IP32 7AR



01284 757500



01284 703534



www.sealey.co.uk



sales@sealey.co.uk