



RETRACTABLE TYPE FALL ARRESTER RESCUE LIFTING DEVICE

Instruction Manual

Reference number:

CRW 300 xx
(xx - working length in meters)



- Connecting handle -for transporting and anchoring to structure
- Casing made of aluminium alloy.
- Cable retractor with energy dissipating brake.
- Informative and identity labels
- Lifting and lowering hand operated winch with automatic brake.
- Working cable made of 4.8mm galvanized wire rope.
- Snap hook with swivel function (Range of alternative hooks with fall indicator as an option)

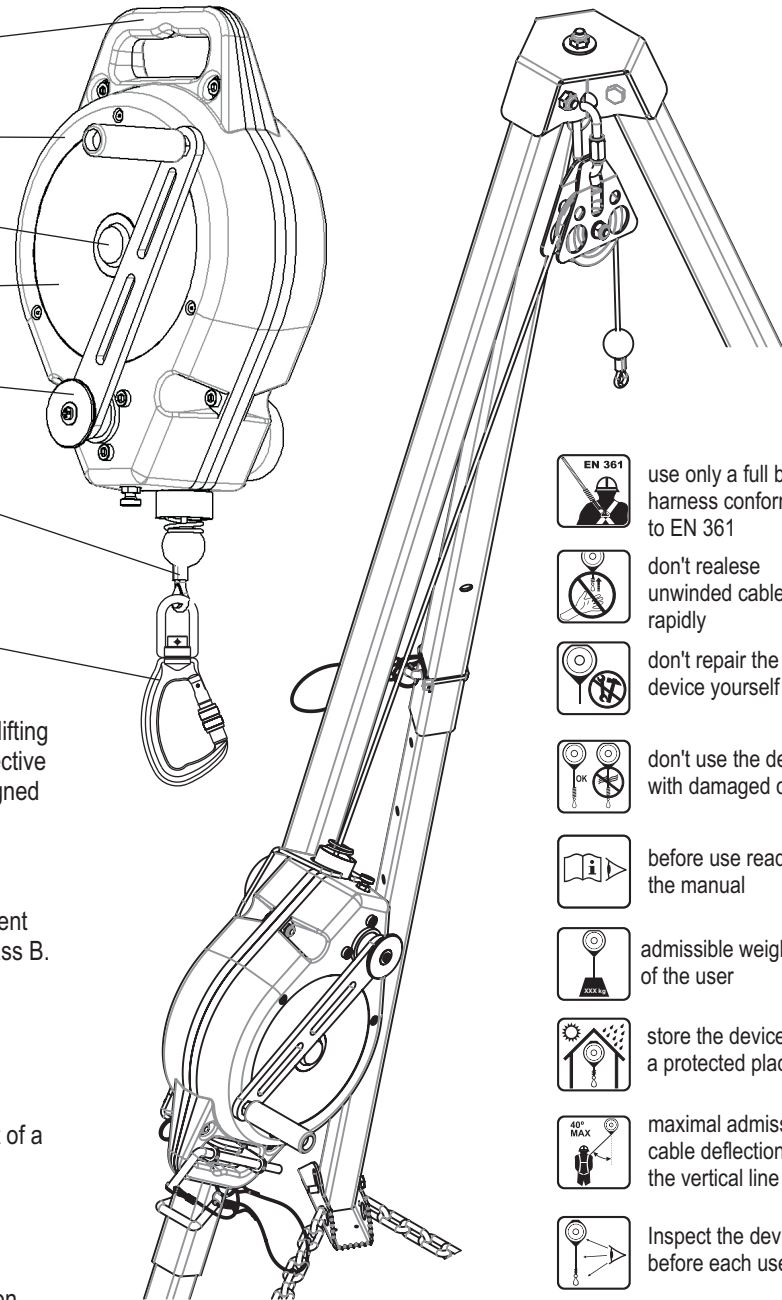

ESSENTIAL FEATURES

The retractable-type fall arrester device including rescue lifting and lowering device is a component of the personal protective equipment against falls from a height. The device is designed for protection one person only.

The device performs two functions relating to prevention against falls from a height - fall arresting function (as a retractable fall arrester) and rescue function. The equipment conforms to the following standards: EN360, EN1496 class B.

TECHNICAL DATA

- max. working load - 140kg;
- min. working load - 50 kg;
- working length - 25 m;
- automatic brake which prevent self-contained descent of a person;
- hand operated winch;

TIME OF USAGE

There is no limit of use of the CRW300 device on condition punctual carried out annual inspections.

MARKING OF THE DEVICE

RETRACTABLE TYPE FALL ARRESTER

Reference No.: **CRW 300 25**

Cable length: **25 m**

Serial number: **0000000**

Date of manufacture: **12.2005**

type of the equipment

reference number of the device including the working length of the device

cable/webbing length

serial number of the device

month and year of manufacture

- use only a full body harness conform to EN 361
- don't release unwinded cable rapidly
- don't repair the device yourself
- don't use the device with damaged cable
- before use read the manual
- admissible weight of the user
- store the device in a protected place
- maximal admissible cable deflection from the vertical line
- Inspect the device before each use
- range of operating temperatures
- check locking before each use

EN 360:2002 — European Standards
EN 1496:2006 class B

CE 0082 — CE mark and number of notified body inspecting the equipment

FORCE — device manufacturer or distributor



Month and year of the manufacturer's next inspection. Don't use the device after this date. Attention: Before the first use mark the date of the first inspection (date of first use +12 months, (e.g. first use 01.2006 - mark inspection 01.2007)

INSTALLING THE CRW 300 ON A STRUCTURAL ANCHOR ELEMENT

It's possible to instal the CRW 300 directly on the structural anchor element (point). The retractable fall arrester shall be installed above the user. An anchor point for the device should have stable structure, and the work carried out in such a way, as to minimise both the potential for falls and potential fall distance. The shape and construction of the anchorpoint shall not allow to self-acting disconnection of the equipment. The minimal strength of the structural anchor point should be 12 kN. It is recommended to use certified and marked structural anchor point or device, conform to the EN795 standard.

Connecting the fall arrester to a structural anchor point should be done by joining the

arrester handle to a structure with the aid of a connector or sling complying with EN362 or EN795 standards (fig.2-1).

When the device is installed in the vertical line above the user the minimal clearance distance below working level shall be 1,5 m.

When the cable of the retractable fall arrester is deflected from vertical line a pendulum effect occurs during fall arresting. In order to minimise the pendulum effect the cable deviation angle from vertical shall never exceed 40°. For this purpose the user is permitted to move laterally through distance "l" not greater than 1/2 "v". The clearance distance below working level must be greater than 1,5 m+ lateral distance "l" (fig. 2-2).

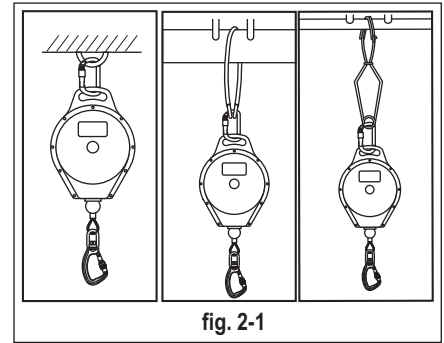

fig. 2-1

UTILIZATION WITH A BODY HARNESS

A full body harness conform to the EN 361 is the only accepted device for keeping a body in the fall arrest system which utilize the CRW300 device. During employment the EN360 function of the device, the device lanyard should be connected only to full body harness fastening points (buckles, loops) marked with the capital letter "A" (fig.2-3). During employment the EN1496 function of the device, apart from the EN361 "A" marked attachment point, the EN1497 attachment point may be used.

A connection between CRW300 device and the harness attachment point should be done with the aid of connector conform to EN 362

standard. Always protect the gate of the snap hook against accidental opening with locking gear.

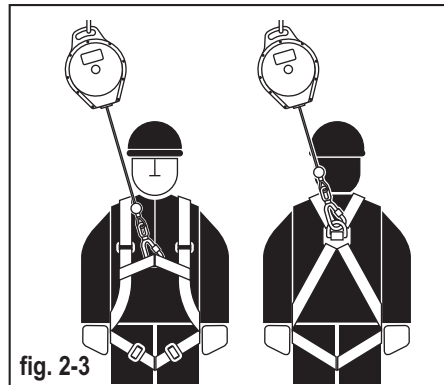

fig. 2-3

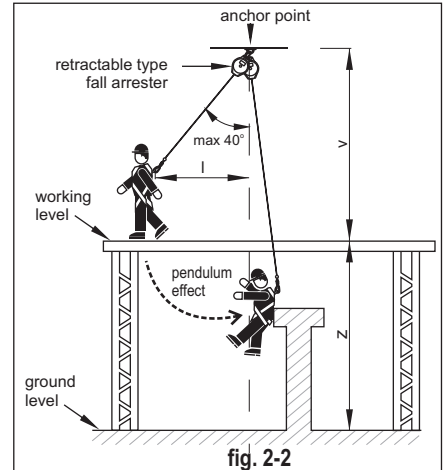

fig. 2-2

UTILIZATION WITH A TRIPOD

The CRW 300 device may be used together with the TM9 / TM11 tripods. Installation on the tripod may be done with the aid of special fixing adapters, respectively: AT 171 (for TM9) and AT172 (for TM11) and the pulley RUP 942 (fig.2-4).

The way of The CRW300 installation on the tripod is described on the fig.2-5.

The CRW300 should be mounted into adapter frame by inserting the cable sleeve into adapter opening (step"1") and than slide onto the adapter fork (step"2"). Secure the CRW device with the aid of the adapter pin (step"3"). After that, unwind the CRW300 cable form the device and belay on the pulley RUP042 (step"4").

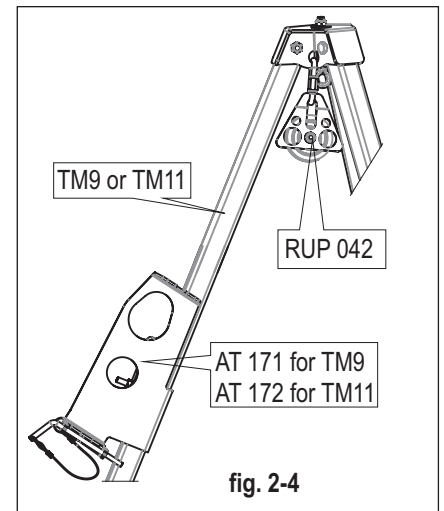

fig. 2-4

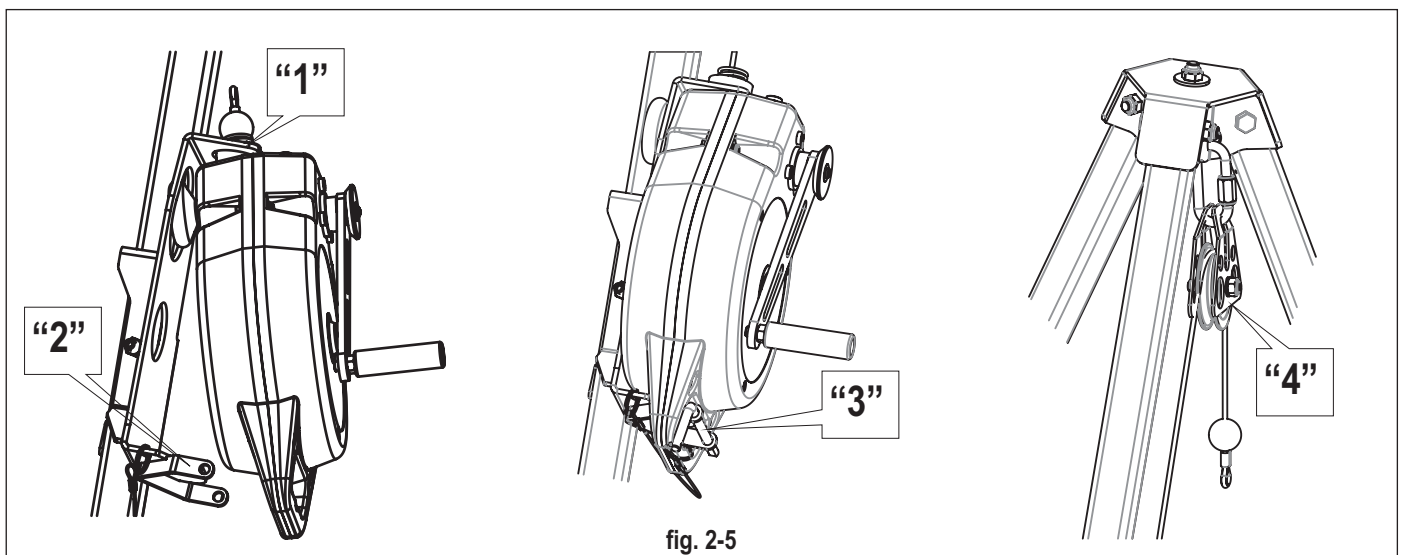

fig. 2-5

SWITCHING BETWEEN EN360 AND EN1496

Only one of the EN360 or EN1496 functions of the device may be applied at the same time. To change the function, the operation described on the fig.3-1 and 3-2 should be done. In particular, to change from EN360 to EN1496 function, pull out the locking pin "a"

and next pull out the crank axle "b" (fig.3-1). Then, in the consequence of cranking, the device cable is moved up or down, under control. The switching from EN360 to EN1496 function may be done especially when the CR300 have arrested a fall and

there is necessity to rescue of the user. In order to change the EN1496 function to EN360 pull out the locking pin "a" and next push in the crank axle "b" inwards (fig. 3-2). Then the device will act as a retractable fall arrester.

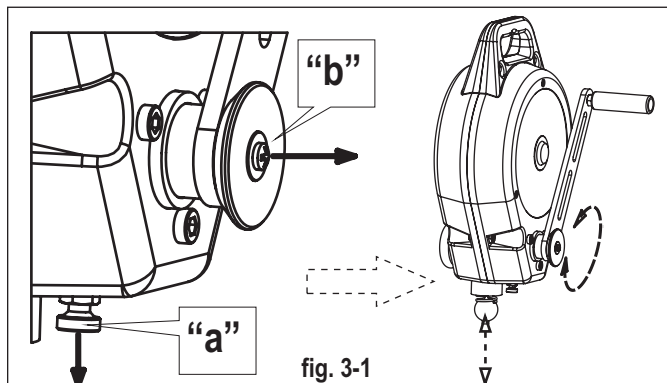

fig. 3-1

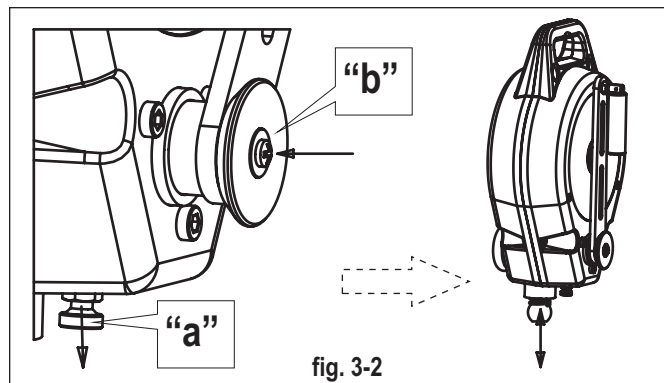

fig. 3-2

CLEANING

External surface of the CRW300 casing and the wire rope lanyard can be cleaned with a wet cloth. Do not use any acid or basic solvents. Cable devices leave to dry in the unwound state. The cable lanyard can be slightly lubricated with machine oil.

STORAGE

The CRW300 device should be stored in a dry, ventilated, room temperature and free of aggressive chemicals places. Before the first usage the device must be stored in manufacturer package.

FUNDAMENTALS RULES OF USING OF A PERSONAL PROTECTIVE EQUIPMENT

- personal protective equipment shall only be used by a person trained and competent in its safe use.
- personal protective equipment must not be used by a person with medical condition that could affect the safety of the equipment user in normal and emergency use.
- a rescue plan shall be in place to deal with any emergencies that could arise during the work.
- it is forbidden to make any alterations or additions to the equipment without the manufacturer's prior written consent.
- any repair shall only be carried out by equipment manufacturer or his certified representative.
- personal protective equipment shall not be used outside its limitations, or for any purpose other than that for which it is intended.
- personal protective equipment should be a personal issue item.
- before use ensure about the compatibility of items of equipment assembled into a fall arrest system. Periodically check connecting and adjusting of the equipment components to avoid accidental loosening or disconnecting of the components.
- it is forbidden to use combinations of items of equipment in which the safe function of any one item is affected by or interferes with the safe function of another.
- before each use of personal protective equipment it is obligatory to carry out a pre-use check of the equipment, to ensure that it is in a serviceable condition and operates correctly before it is used.
- during pre-use check it is necessary to inspect all elements of the equipment in respect of any damages, excessive wear, corrosion, abrasion, cutting or incorrect acting, especially in retractable fall arresters - cable or webbing retracting and locking function;
- Regular periodical inspections are essential in terms of equipment condition and safety of users. Only fully operational equipment is able to provide safety. The retractable fall arrester must be withdrawn from use and undergo a complete periodical inspection and maintenance, at least once a year (after 12 months of use). The inspection must be carried out by the equipment manufacturer or an authorised representative of the manufacturer. Such an inspection should check all equipment elements and functions according valid producer Service Manual. The date of the subsequent inspection shall be specified after the periodical inspection has been completed.
- it is essential for the safety of the user that if the product is re-sold outside the original country of destination the reseller shall provide instructions for use, for maintenance, for periodic examination and for repair in language of the country in which the product is to be used.

The factory where equipment is stored/ used is responsible for keeping the Operation Sheet for a particular device. The Sheet should include at least: the

device name, serial number, date of purchase and date of first operation, user name, information concerning repairs and inspections and withdrawal from use. The Sheet should be completed by the person responsible for safety equipment in a given place of work. Equipment without a properly completed Operation Sheet cannot be used.

personal protective equipment must be withdrawn from use immediately when any doubt arise about its condition for safe use and not used again until confirmed in writing by equipment manufacturer or his representative after carried out the detailed inspection.

- An anchor device or anchor point for the fall arrest system should have stable structure, and the work carried out in such a way, as to minimise both the potential for falls and potential fall distance. The anchor device/point should be placed above the user. The shape and construction of the anchor device/point shall not allowed to self-acting disconnection of the equipment. It is recommended to use certified and marked structural anchor point with the EN795 standard. The minimal strength of any other structural anchor point should be 12 kN.
- it is obligatory to verify the free space required beneath the user at the workplace before each occasion of use the fall arrest system, so that, in the case of a fall, there will be no collision with the ground or other obstacle in the fall path. The required value of the free space should be taken from instruction manual of used equipment.
- there are many hazards that may affect the performance of the equipment and corresponding safety precautions that have to be observed during equipment utilization, especially:- trailing or looping of device lanyard over sharp edges,- pendulum falls,- extreme temperature,- chemical reagents,- electrical conductivity; -dust laden and greasy environment.
- personal protective equipment must be transported in the package (e.g.: bag made of moisture-proof textile or foil bag or cases made of steel or plastic) to protect it against damage or moisture.
- the equipment can be cleaned without causing adverse effect on its materials. For textile products use mild detergents for delicate fabrics, wash by hand or in a machine and rinse in water. Plastic parts can be cleaned only with water. When the equipment becomes wet, either from being in use or when due cleaning, it shall be allowed to dry naturally, and shall be kept away from direct heat. In metallic products some mechanic parts (spring, pin, hinge, etc.) can be regularly slightly lubricated to ensure better operation. Other maintenance and cleaning procedures should be adhered to detailed instructions stated in the Service Manual of the equipment.
- personal protective equipment should be stored loosely packed, in a well-ventilated place, protected from direct light, ultraviolet degradation, damp environment, sharp edges, extreme temperatures and corrosive or aggressive substances.

IDENTITY CARD of a personal protective equipment

It is the responsibility of the user organisation to provide the identity card and to fill in the details required.

The identity card should be filled in only by a competent person responsible for protective equipment.

The identity card should be filled in before the first use of the equipment.

Any information about the equipment like: periodic inspections, repairs, reasons of equipment's withdrawn from use shall be noted.

The identity card should be stored during a whole period of equipment utilization. Do not use the equipment without the identity card.

MODEL AND TYPE OF EQUIPMENT	
REF. NUMBER	
SERIAL NUMBER	
DATE OF MANUFACTURE	
DATE OF PURCHASE	
DATE OF FIRST USE	
USER NAME	

SafetyLiftinGear.com
 Unit RTD Rockingham Gate Poplar Way
 West Cabot Park Bristol BS11 0YW
 Tel: 0808 123 69 69 Fax: 0117 9381
 602.sales@safetyliftgear.com

Notified body, at which the European certification was issued
 and which supervises the production of the equipment:
 APAVE SUDEUROPE SAS - 8 rue Jean-Jacques Vermezzo -
 CS-60193 - 13322 MARSEILLE Cedex 16, France - No. 0082
 PRODUCENT: PROTEKT, 9-3403 LODZ, ul. Starorudzka 9, POLAND,
 TEL: [48 42] 680 20 83, FAX: [48 42] 680 20 93, www.prolekt.com.pl

PERIODIC EXAMINATION AND REPAIR HISTORY

	DATE	REASON FOR SERVICING / REPAIR	CONDITION OF DEVICE AFTER SERVICING	NAME AND SIGNATURE OF COMPETENT PERSON	DATE OF NEXT EXAMINATION
1					
2					
3					
4					
5					
6					
7					
8					
9					
10					
11					