



Lifting Points - for bolting - Load Ring bolted - VWBG-V -

– 360° swivelling/230° pivoting –



Complies with the machinery directives 2006/42/EG

**4 SAFETY
FACTOR 4:1
LOADABLE IN
ANY DIRECTION**

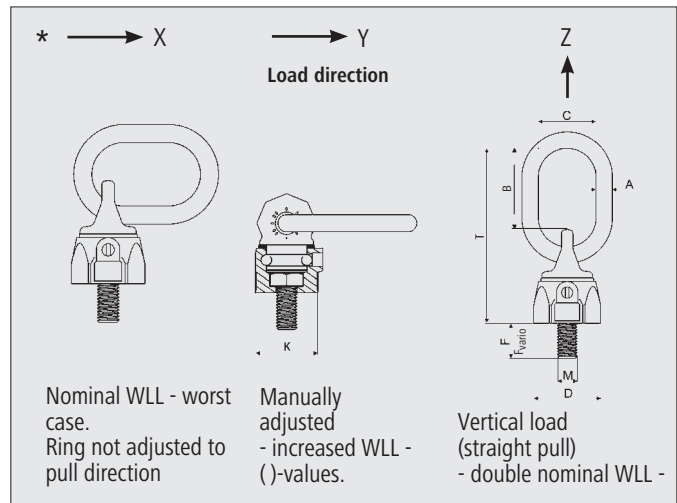
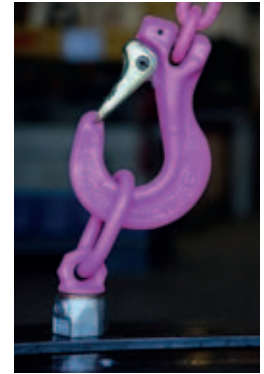
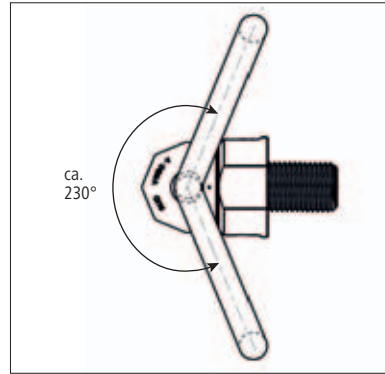
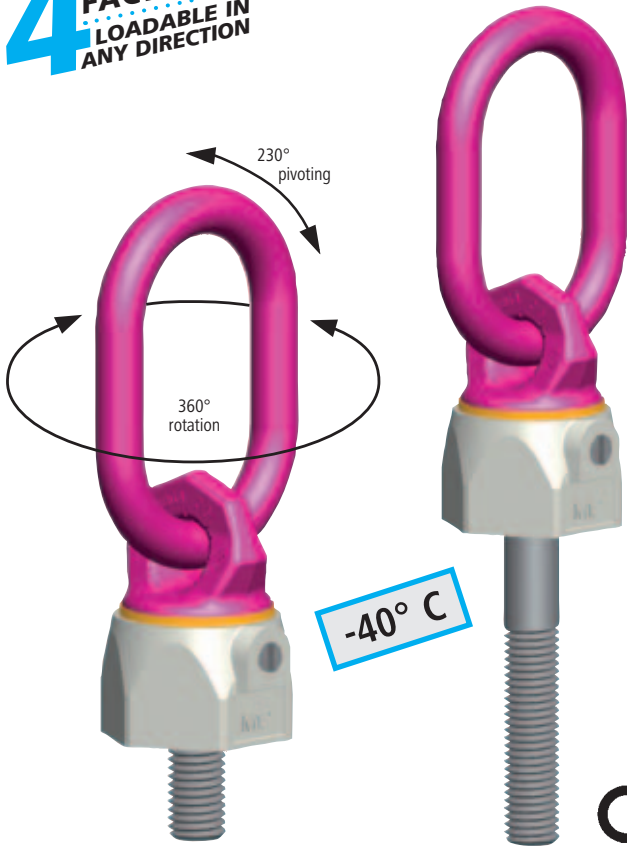

Type	WLL [t]	A [mm]	B [mm]	C [mm]	D [mm]	F _{stand.} [mm]	F _{vario} [mm]	K [mm]	M [mm]	T [mm]	X [mm]	Ref.-No. Stand.	Ref.-No. Vario with washer and nut
VWBG-V 0.3 M8	0.3(0.4)	8	31	29	30	13	8-102	28	8	76	18	7103720	8600330
VWBG-V 0.45 M10	0.45(0.6)	8	31	29	36	17	10-122	30	10	78	19	7103715	8600331
VWBG-V 0.6 M12	0.6(0.7)	10	49	35	42	21	12-140	36	12	107	19	7100180	8600332
VWBG-V 1.0 M14	1.0(1.25)	13	46	38	48	21	14-65	41	14	113	–	–	8600337
VWBG-V 1.3 M16	1.3(1.5)	13	46	38	48	25	16-180	41	16	113	28	7100430	8600333
VWBG-V 1.8 M18	1.8(2.0)	13	54	35	62	27	18-83	55	18	137	–	–	8600338
VWBG-V 2.0 M20	2.0(2.5)	13	54	35	62	33	20-223	55	20	137	30	7100800	8600334
VWBG-V 2.0 M22	2.0(2.5)	13	54	35	62	33	22-94	55	22	137	–	–	8600334
VWBG-V 3.5 M24	3.5(4.0)	18	66	40	81	40	24-255	70	24	173	25	7100640	8600335
VWBG-V 3.5 M27	3.5(4.0)	18	66	40	81	40	27-92	70	27	173	–	–	8600335
VWBG-V 5.0 M30	5.0(6.0)	22	90	50	99	50	30-330	85	30	221	32	7100650	8600336

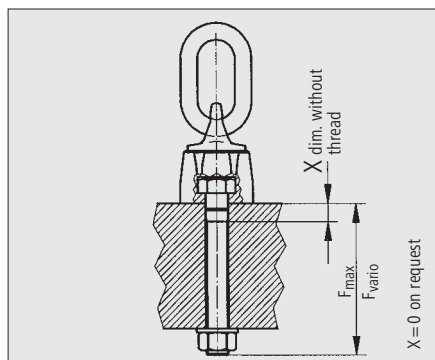

Example to investigate the required thread length Fvario:
Fvario: Plate thickness 50 mm, through hole for M 20 bolt, height of nut 22 mm, thickness of the washer 3 mm, plus bolt projection 5 mm = 80 mm.
Order length: VWBG-V-2.0 M 20 x 80.

***Caution:** During lifting, the ring of the lifting point can engage in any position. The embossed WLL is for the worst case scenario (see image X). If the ring is manually adjusted to the horizontal position, higher WLL values in brackets () can be chosen (see image Y). In case of straight pull (see image Z: vertical load direction) Maximum WLL can be chosen. The nominal WLL can be increased acc. the chart from page 7!

Swivelling lifting point:

- Loadable in any direction. Safety factor 4 : 1.
- Turnable under load in vertical direction.
- Not suitable for permanent swivelling under full load, especially in 90° direction.
- Simple installation, just a thread hole is required.
- Variable lengths (Vario) available.
- Can also be used for through holes.
- Bolts 100 % magnetic crack detected! Surface protection CORRUD-DT (20 times better than zinc plating).
- High tensile, approved suspension ring acc. EN 1677-4.
- Surface: Ring pink powder coating, housing zinc plated.
- Type Vario with washer and 100 % crack detected nut.
- VWBG-V and VWBG are also available with Imperial thread.
- Turning without jerk due to additional bush bearing washer.
- Wear marks in the main load directions 45°, 60° and 90°.